

Features

- Wide operating voltage: 3.0V ~ 5.5V
- Output Current up to 12A
- Output voltage: 0.84~3.63V
- Fixed output available – ME7182L
- Output voltage ripple: 20mV_{PP}
- High Efficiency 95%
- Temperature-adaptive overcurrent /shortcircuit protection*
- Over-temperature protection
- Remote on/off control - negative logic
- High reliability: designed to meet 5 million hour MTBF
- Output voltage remote sense compensation ("s" suffix)
- No external bias required
- **StrongThumb™** minimal space on PCB:
 - 50.8 mm x 8mm x 12.7 mm or
 - 2.0 in x 0.31in x 0.50in
- No derating to +50°C, natural convection
- UL/IEC/EN60950 compliant
- RoHS Compliant available

* Patent Pending

Applications

- Workstations, servers
- Desktop computers
- DSP applications
- Distributed power architectures
- Telecommunications equipment
- Data communications equipment
- Wireless communications equipment

Options

- Output voltage remote sense
- Right Angle

Description

The **StrongThumb™** ME7182L-ADJ Series Power Modules are non-isolated dc-dc converters that operate over a wide input voltage range of 3Vdc to 5.5Vdc and provide a precisely (2%) regulated dc output with industry standard SIP pin out. Such a module is suitable to application with a 3.3V or 5V power supply system. The modules have a maximum output current rating of 12A at a typical full-load efficiency over 90%. Standard features include remote on/off with negative logic and output voltage trimmable, over-current protection, over-temperature protection. Option features include output voltage remote sense compensation, right angle.

***** **Typical Application Circuit** *****

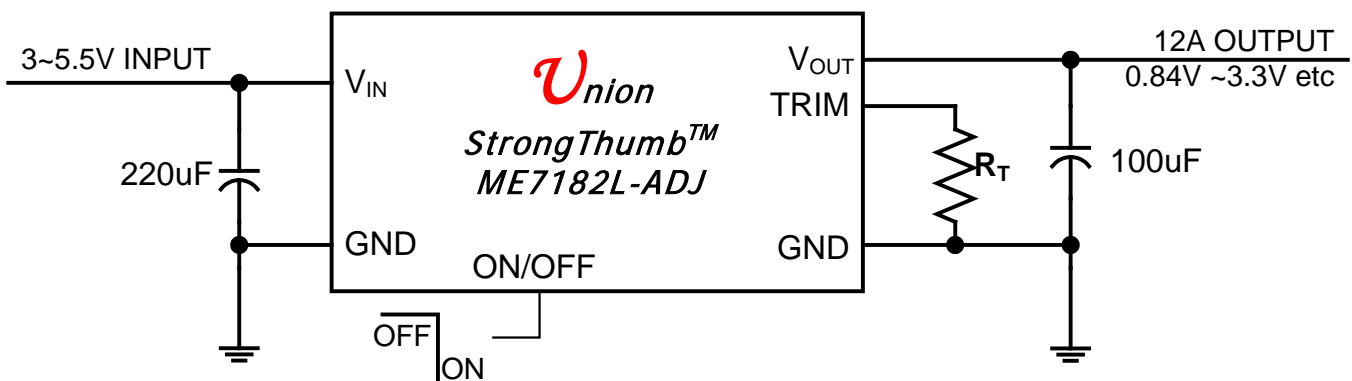

Performance Specifications (at TA=+25°C)

Model	Input V_{IN} Range(V)	Output			
		I_{OUT} (A)	Trim Range(V)	Regulation	
				Line (%)	Load (%)
ME7182L-ADJ	3 ~ 5.5	12	0.84 ~ 3.63	0.5	0.5

Mechanical Specifications

Dimensions are in inches (mm)

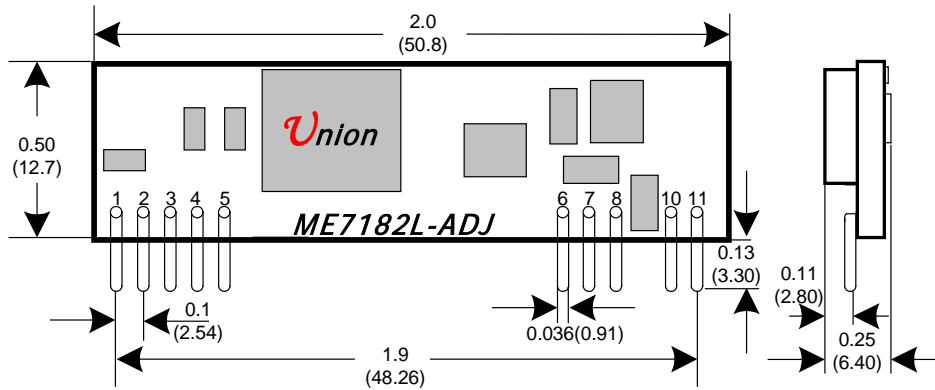

PIN	DESCRIPTION
1	V_{OUT}
2	V_{OUT}
3	SENSE ("S" suffix)
4	V_{OUT}
5	GND
6	GND
7	V_{IN}
8	V_{IN}
9	No PIN
10	TRIM
11	ON/OFF

Front View ("R" suffix see also Page13)

Ordering Information

ME7182L - ADJ - SRG

Union Microsystems
Power module P/N

Output Voltage Range
0.84~3.63V

Green Product
(RoHS Compliant)

Right Angle Option

Remote Sense Option

Absolute Maximum Ratings

Note: These are stress ratings. Exposure of devices to any of these conditions may adversely affect long-term reliability. Proper operation under conditions other than those listed in the Performance Specifications Table is not implied.

Parameter	Symbol	Min	Max	Unit
Input Voltage	V_{IN}	-0.3	6	V
Storage Temperature	T_{STG}	-40	125	°C

ME7182L-ADJ Electrical Specifications: ($T_A=+25^\circ\text{C}$)

Parameter	Condition	Symbol	Min	Typ	Max	Unit
Input Voltage Range		V_{IN}	3		5.5	V
Output Current		I_O	0		12	A
Output Voltage Set point	100% load	ΔV_O	-2		+2	%
Output Trim Range	See Performance Specifications					
Line Regulation						
Load Regulation						
Output Ripple and Noise Voltage	$V_{IN}=V_{IN, nom}$ and $I_O=I_{O, min}$ to $I_{O, max}$ $C_{OUT}=1\mu\text{F}$ ceramic// $10\mu\text{F}$ tantalum capacitors RMS (5Hz ~ 20MHz bandwidth)			8	20	mVrms
	$V_{IN}=V_{IN, nom}$ and $I_O=I_{O, min}$ to $I_{O, max}$ $C_{OUT}=1\mu\text{F}$ ceramic// $10\mu\text{F}$ tantalum capacitors Peak-to-Peak (5Hz ~ 20MHz bandwidth)			20	50	mVpp
Efficiency	$V_{in}=3.3\text{V}$, $I_O=12\text{A}$	$V_O=0.84\text{V}$			84.5	%
		$V_O=1.2\text{V}$			87.6	
		$V_O=1.5\text{V}$			89.7	
		$V_O=1.8\text{V}$			91	
		$V_O=2.0\text{V}$			91.5	
		$V_O=2.5\text{V}$			93	
	$V_{in}=5\text{V}$, $I_O=12\text{A}$	$V_O=0.84\text{V}$			82	
		$V_O=1.2\text{V}$			82	
		$V_O=1.5\text{V}$			87	
		$V_O=1.8\text{V}$			89	
		$V_O=2.0\text{V}$			91	
		$V_O=2.5\text{V}$			92	
				93		

General Specifications

Parameter	Condition	Symbol	Min	Typ	Max	Unit
Maximum Capacitive Load	12A resistive load + Aluminum capacitor			6600		μF
	12A resistive load + Sanyo POSCAP			2000		
Overcurrent Protection			15		24	A
Output short-circuit current (average)	All				2	A
Under Voltage Lockout Trip Level	Rising and falling V_{IN} , 3% hysteresis		2.50	2.8	2.95	V
Logic High (Module OFF)		V_{IH}	2.8		6.5	V
Logic Low (Module ON)		V_{IL}	-0.7		0.3	V
Start-up Time	12A resistive load, no external output capacitors			15		mS
Switching Frequency		F_o		300		kHz
Operating Temperature	Natural convection, no forced air flow (with derating of $0.5\text{W}/^\circ\text{C}$ when $T_A \geq +55^\circ\text{C}$)		-25		70	°C
Vibration	3 Axes, 5 Min Each	10~55Hz, 0.35mm, 5g				
	3 Axes, 6 Times Each	Peak Deviation 300g, Settling Time 6mS				
MTBF				5,000,000		Hour

Test Configurations

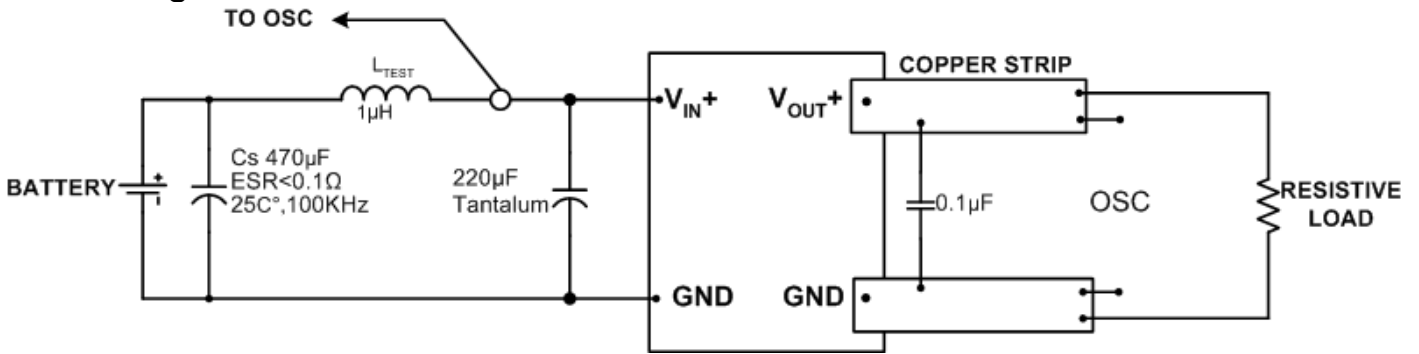

Note:

Output noise is measured with 0.1µ F ceramic capacitor connected at the output. OSC measurement should be made using a BNC socket. Position the load between 50mm and 75mm (2in. and 3in) from the tested module.

Technical Notes

Input Voltage Range

The ME7182L-ADJ Series can be used in a wide variety of applications, esp. most of 3.3V or 5V power supply bus system. So, when system voltage transferred from 5V to 3.3V or vice versa, no redesign needed which simplifies design, speeds the time to market and adds flexibility to system.

Return Current Paths

The ME7182L-ADJ Series is non-isolated DC/DC converters. Their two Common pins (pins 5 and 6) are connected to each other internally. To the extent possible with the intent of minimizing ground loops, input return current should be directed through pin 6 (also referred to as---Input or Input Return), and output return current should be directed through pin 5 (also referred to as---Output or Output Return).

I/O Filtering

All the specifications of the ME7182L-ADJ Series are tested and specified without output capacitors. However, certain input capacitors are necessary to improve the power modules' operating conditions and to reduce the ac impedance. For example, under some conditions, the power modules can't normally start up when fully loaded due to the high ac-impedance input source. External input capacitors serve primarily as energy-storage devices. They should be added close to the input pins of the ME7182L-ADJ and selected for bulk capacitance (at appropriate frequencies), low ESR, and high rms-ripple-current ratings. All external capacitors should have appropriate voltage ratings. To reduce the amount of ripple current fed back to the input supply (input reflected-ripple current), an external L-C filter can be added with the inductance as close to the power module as possible.

ME7182L-ADJ's output ripple and transient response can be improved with the increasing output capacitance. When using output capacitors, take care that the total output capacitance does not exceed ME7182L-ADJ's Maximum Capacitive Load to avoid the module's protection condition in the start-up.

When an external L-C filter is added to reduce ripple on load, for best results, the filter components should be mounted close to the load circuit rather than the power module.

When testing the relationship between external capacitors and output voltage noise, the oscilloscope's probe should be applied to the module's end directly with scope probe ground less than 10mm in length.

Input Fusing

The ME7182L-ADJ Series is not internally fused. Certain applications and/or safety agencies may require the installation of fuses at the inputs of power conversion components. The selection of the fuses should conform to the following:

1. The fuse value should be selected to be greater than the maximum input current of the module which occurs at the minimum input voltage.
2. Use either slow-blow or normal-blow fuses.
3. Both input traces must be capable of carrying a current of 1.5 times the value of the fuse without opening.

Safety Considerations

ME7182L-ADJ's are non-isolated DC/DC converters. In general, all DC-DC's must be installed in compliance with relevant safety-agency specifications (usually UL/IEC/EN60950). In particular, for a non-isolated converter's output voltage to meet SELV (safety extra low voltage) requirements, its input must be SELV compliant. If the output needs to be ELV (extra low voltage), the input must be ELV.

Remote Sense

ME7182L-ADJ Power Modules with suffix "S" offer an output sense function on pin 3. The sense function enables point-of-use regulation for overcoming moderate IR drops in conductors and/or cabling. The sense line carries very little current and consequently requires a minimal cross-sectional-area conductor. As such, it is not a low-impedance point and must be treated with care in layout and cabling. Sense lines should be run adjacent to signals (preferably ground).

Use of trim and sense functions can cause the output voltage to increase, thereby increasing output power beyond the ME7182L-ADJ's specified rating. Therefore:

$$V_{OUT} \text{ (at pins)} \times I_{OUT} \leq P \text{ (rated output power)}$$

Note: If devices have the +Sense pin (pin3) installed and the sense function is not used for remote regulation, +Sense (pin3) must be tied to +Output (pin4) at the DC/DC converter pins.

ON/OFF Control

The ME7182L-ADJ power modules feature an On/Off pin for remote On/Off operation. If not using the remote On/Off pin, leave the pin open (module will be On). The On/Off pin signal ($V_{On/Off}$) is referenced to ground. To switch module on and off using remote On/Off, connect an open collector pnp transistor between the On/Off pin and the V_{IN} pin (See Figure 1a). During a logic-low when the transistor Q_{EN} inside power module is in the Off state, the power module is ON and the maximum $V_{On/off}$ of the module is 0.4 V. The maximum allowable leakage current of Q_{EN} when $V_{On/off} = 0.4V$ and $V_{IN} = 5.5V$ is 100uA. During a logic-high when Q_{EN} is in the active state, the power module is OFF. During this state $V_{On/Off} = 2.5V$ to $5.5V$ and the maximum $I_{On/Off} = 1mA$.

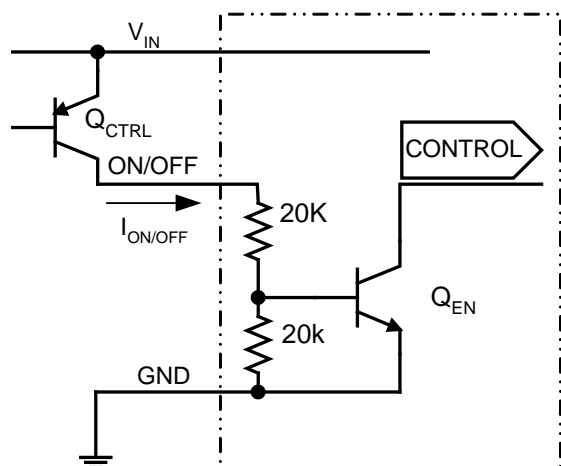

Fig1a. Remote ON/OFF Implementation with pull-up pnp transistor

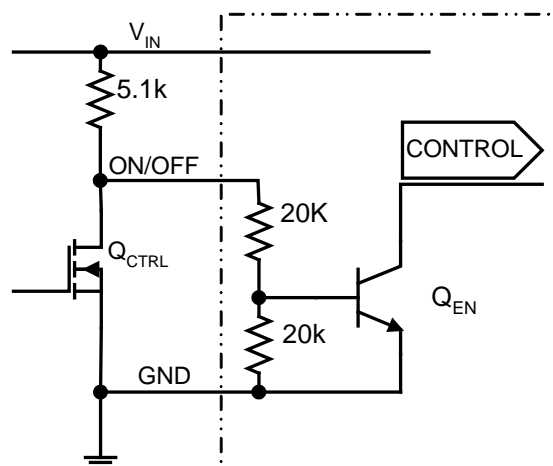

Fig1b. Remote ON/OFF Implementation with Open Collector/Drain transistor

Remote On/Off can also be implemented using open collector/ drain logic devices with an external pull-up resistor. Figure1b shows the circuit configuration using this approach. 5.1k (+/- 5%) pull-up resistor is for proper operation of module function over the entire temperature range.

Output Overvoltage Protection

ME7182L-ADJ Series products do not incorporate output overvoltage protection. If the operating circuit requires protection against abnormal output voltage, voltage-limiting circuitry must be provided external to the power module.

Output Overcurrent Protection (OCP)

ME7182L-ADJ incorporates overcurrent and short circuit protection. If the load current exceeds the overcurrent protection setpoint, the ME7182L-ADJ's internal overcurrent-protection circuitry immediately turns off the module, which then goes into Hiccup mode. The unit operates normally once the output current is brought back into its specified range. The typical average output current during hiccup is 1~2A.

Caution: Be careful never to operate ME7182L-ADJ in a "heavy overload" condition that is between the rated output current and the overcurrent protection setpoint. This can cause permanent damage to the components.

Overtemperature Protection (OTP)

To ensure ME7182L-ADJ's reliability and avoid damaging its internal components, ME7182L-ADJ incorporates overtemperature protection circuit. When the temperature of the PCB is above 110°C, the overtemperature protection circuit will be enabled and the module will stop working. when the temperature of the temperature-testing component is below about 80°C, the overtemperature protection circuit will release and the module will automatically recover from shutdown. To avoid permanently damaging components, the surface temperature of ME7182L-ADJ's power components, esp. of the MOSFET should be ensured below 110°C.

Note: The overtemperature protection may be issued when ME7182L-ADJ operates in a “heavy overload” condition for a long time. Thus, the air flow should be improved.

Output Voltage Programming

The output voltage of ME7182L-ADJ can be programmed to any voltage from 0.84Vdc to 3.3Vdc by connecting a single resistor (shown as R_{TRIM} in Figure 2) or one pair of resistor combination between the TRIM and GND pins of the module. Without an external resistor between the TRIM pin and the ground, the output voltage of the module is 0.84Vdc. To calculate the value of the resistor R_{TRIM} for a particular output voltage V_o , use the following equation:

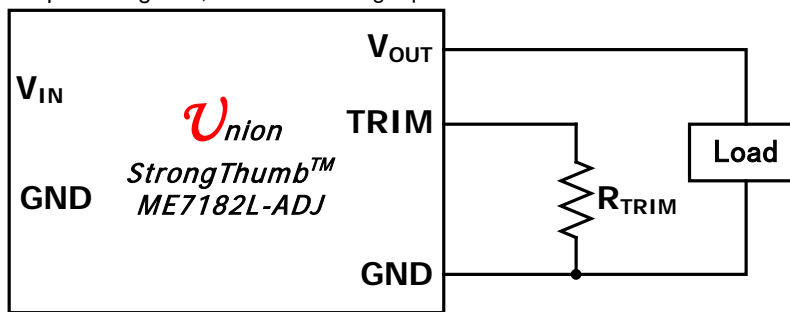

Figure 2, Circuit configuration for programming output voltage using an external resistor

$$R_{TRIM} = \frac{12.64}{V_o - 0.84} - 4.53$$

Resistor values are in kΩ.

For example to program the output voltage of ME7182L-ADJ to 1.8V, R_{TRIM} is calculated as following:

$$R_{TRIM} = \frac{12.64}{1.8 - 0.84} - 4.53 = 8.637k\Omega$$

Because the R_{TRIM} value is not a standard E-series value, it can achieve by using two paralleled 1% tolerance resistors, for above examples they are 15.4kΩ and 19.6kΩ

Table 1: Resistor values for some voltages:

V_o , (V)	R_{TRIM} (kΩ)	Referenced E96-series Standard Resistor Combination
0.84	OPEN	N/A
1.2	30.58	53.6kΩ // 71.5kΩ
1.25	26.30	41.2kΩ // 71.5kΩ
1.3	22.95	40.2kΩ // 53.6kΩ
1.5	14.62	19.6kΩ // 57.6kΩ
1.8	8.637	15.4kΩ // 19.6kΩ
2.0	6.367	10.7kΩ // 15.4kΩ
2.5	3.084	4.32kΩ // 10.7kΩ
3.3	0.608	0.649kΩ // 10.7kΩ

By using a set of 1% tolerance trim resistor, set point tolerance of ±2% is achieved as specified in the electrical specification.

ME7182L-ADJ can also be programmed by applying a voltage between the TRIM and GND pin(Figure 3). The following equation can be used to determine the value of V_{TRIM} needed to obtain a desired output voltage V_o :

$$V_{TRIM} = 0.8 - 0.2867 * (V_o - 0.84)$$

For example to program output voltage of ME7182L-ADJ power module to 1.8V, then V_{TRIM} is calculated as follows:

$$V_{TRIM} = 0.8 - 0.2867 * (1.8 - 0.84) = 0.5248V$$

For applications that operating voltage less than 0.84V, it can be achieved by applying one higher voltage to TRIM pin. For examples for desired voltage 0.75V, as calculated as above $V_{TRIM} = 0.8258V$.

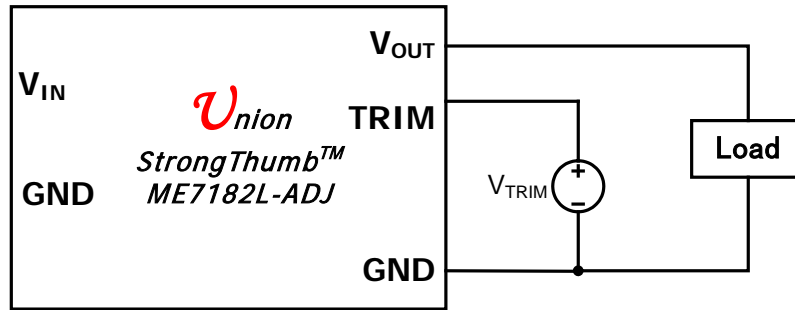

Figure 3, Circuit configuration for programming output voltage using an external voltage source

Table 1: Trim Voltages for desired voltages:

V_o , (V)	V_{TRIM} (V)
0.6	0.8689
0.75	0.8528
0.84	OPEN
1.2	0.6968
1.25	0.6824
1.3	0.6681
1.5	0.6108
1.8	0.5248
2.0	0.4674
2.5	0.3241
3.3	0.0947

Transient Response Performance

(See test configuration)

$V_{IN}=5V, V_{OUT}=3.3V, 6A \text{ to } 12A \text{ to } 6A \text{ Load Step, } C_{in}/C_o=0\mu F$

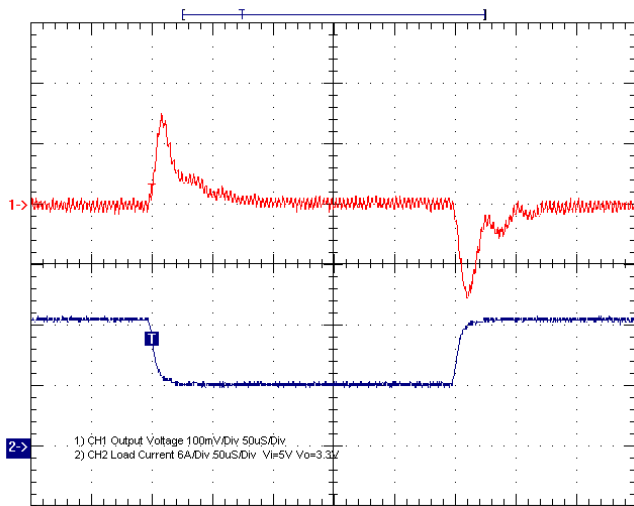

$V_{IN}=5.0V, V_{OUT}=2.5V, 6A \text{ to } 12A \text{ to } 6A \text{ Load Step, } C_{in}/C_o=0\mu F$

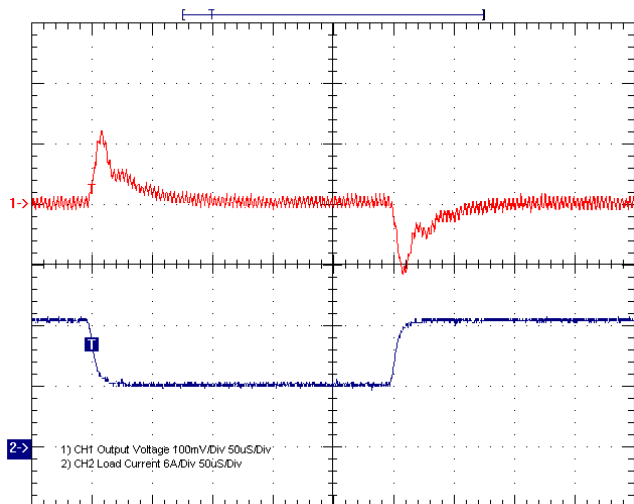

$V_{IN}=3.3V, V_{OUT}=2.5V, 6A \text{ to } 12A \text{ to } 6A \text{ Load Step, } C_{in}/C_o=0\mu F$

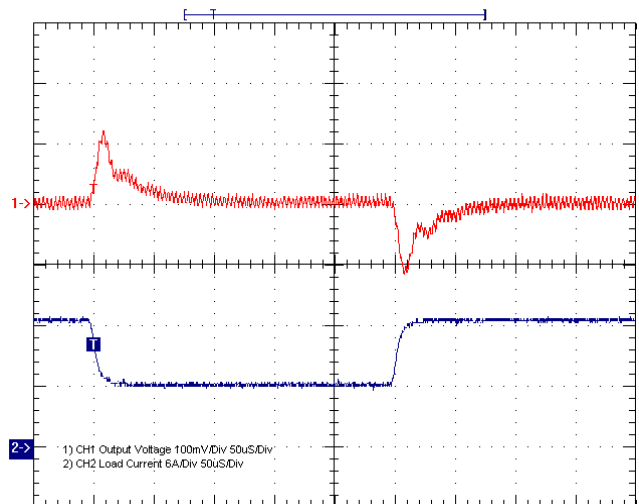

$V_{IN}=5.0V, V_{OUT}=1.8V, 6A \text{ to } 12A \text{ to } 6A \text{ Load Step, } C_{in}/C_o=0\mu F$

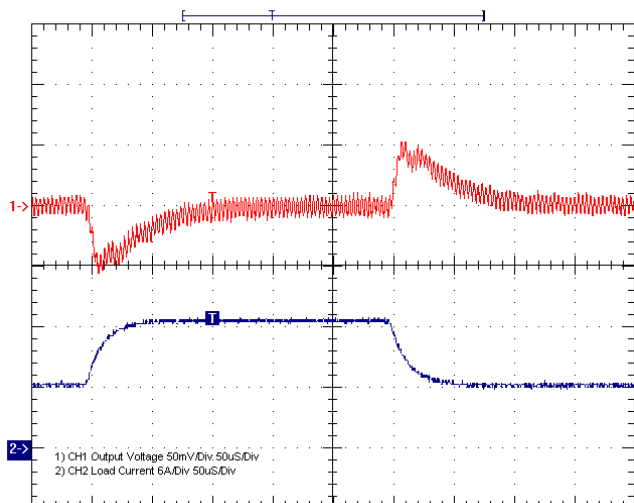

$V_{IN}=3.3V, V_{OUT}=1.8V, 6A \text{ to } 12A \text{ to } 6A \text{ Load Step, } C_{in}/C_o=0\mu F$

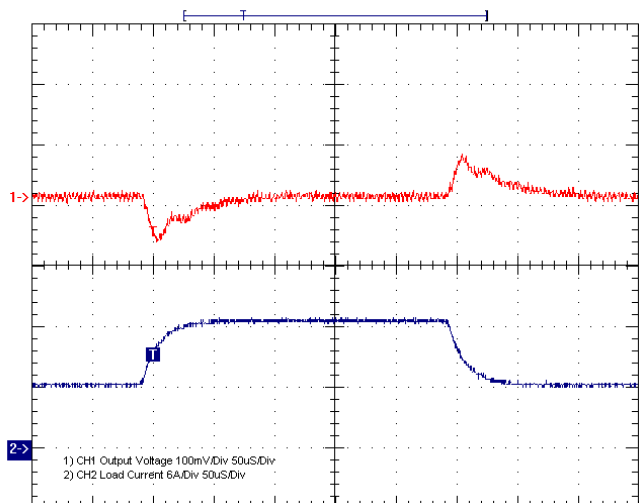

$V_{IN}=5.0V, V_{OUT}=1.5V$, 6A to 12A to 6A Load Step, $C_{in}/C_o=0\mu F$

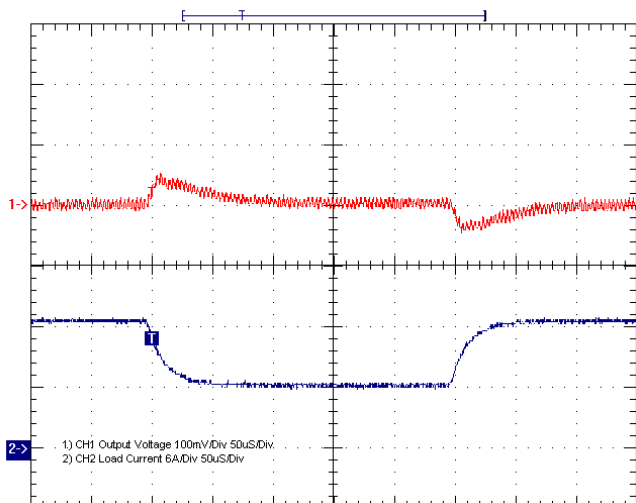

$V_{IN}=3.3V, V_{OUT}=1.5V$, 6A to 12A to 6A Load Step, $C_{in}/C_o=0\mu F$

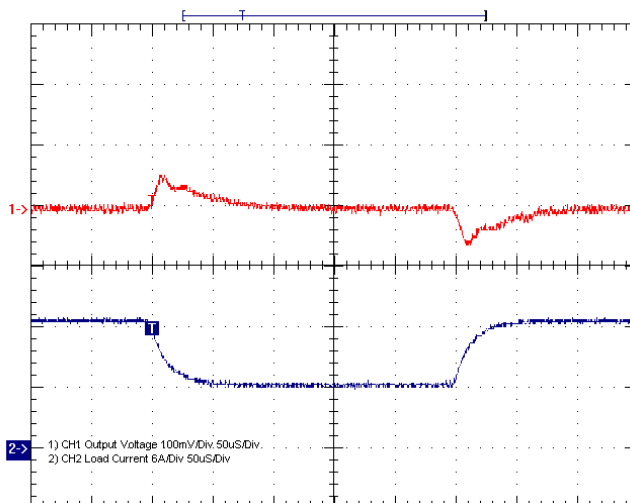

$V_{IN}=5.0V, V_{OUT}=1.2V$, 6A to 12A to 6A Load Step, $C_{in}/C_o=0\mu F$

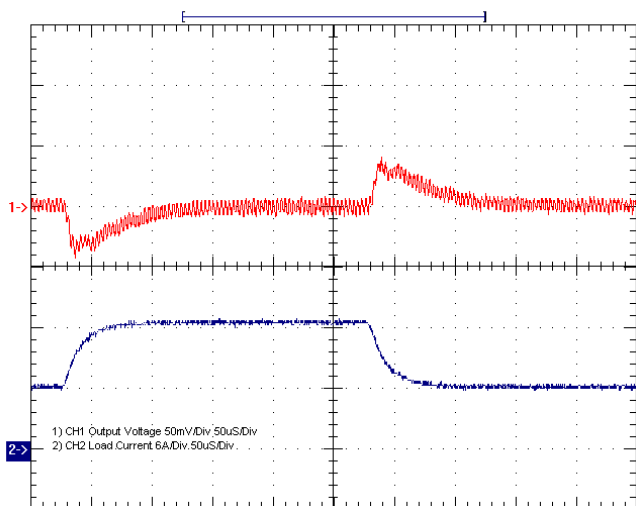

$V_{IN}=3.3V, V_{OUT}=1.2V$, 6A to 12A to 6A Load Step, $C_{in}/C_o=0\mu F$

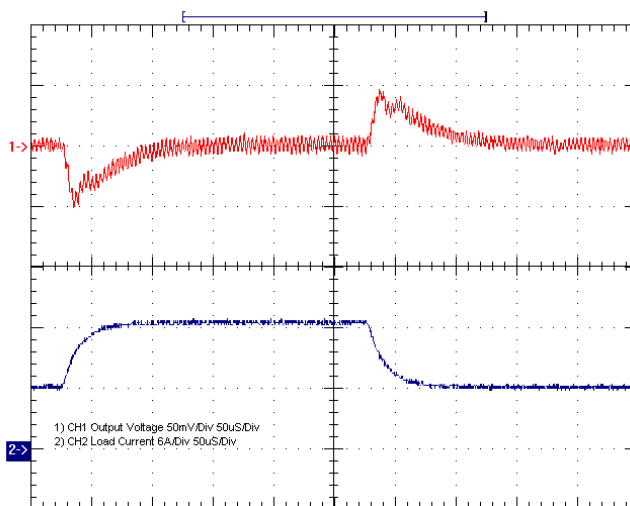

$V_{IN}=5.0V, V_{OUT}=1.0V$, 6A to 12A to 6A Load Step, $C_{in}/C_o=0\mu F$

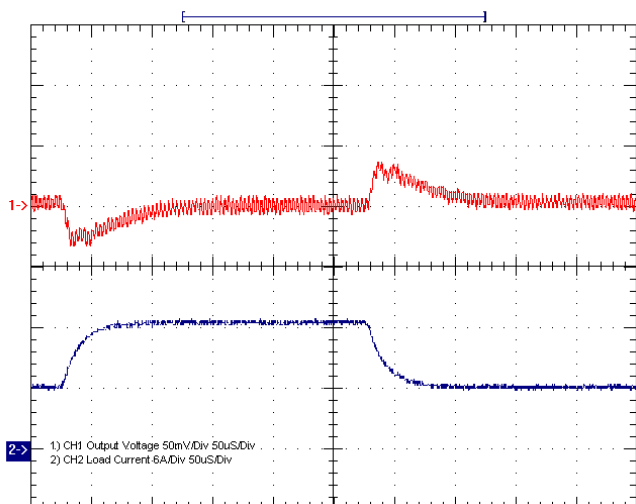

$V_{IN}=3.3V, V_{OUT}=1.0V$, 6A to 12A to 6A Load Step, $C_{in}/C_o=0\mu F$

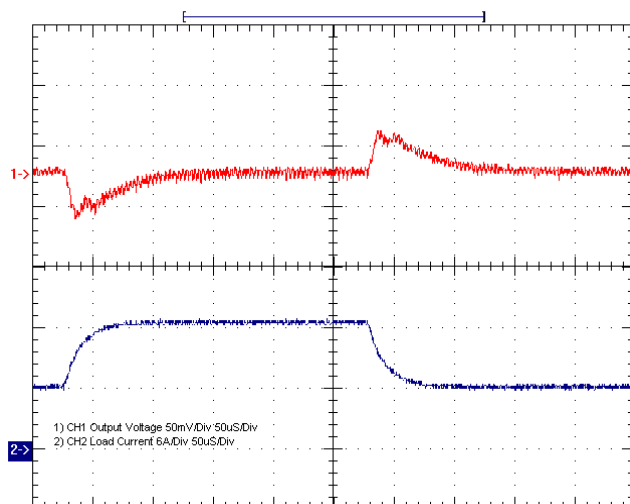

$V_{IN}=5.0V, V_{OUT}=0.9V, 6A \text{ to } 12A \text{ to } 6A \text{ Load Step, } C_{in}/C_{o}=0\mu F$

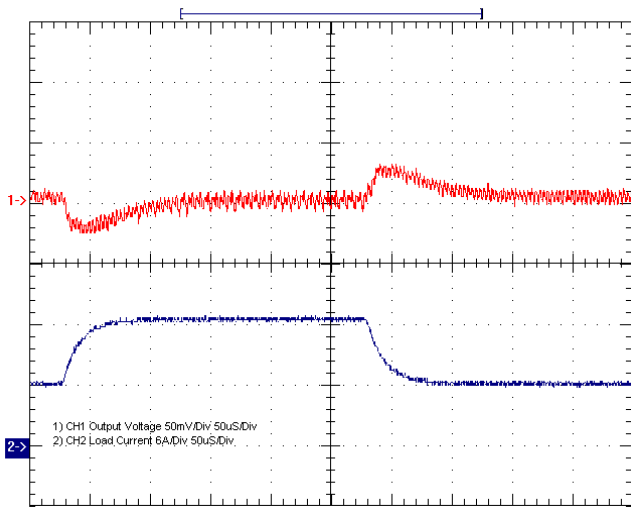

$V_{IN}=3.3V, V_{OUT}=0.9V, 6A \text{ to } 12A \text{ to } 6A \text{ Load Step, } C_{in}/C_{o}=0\mu F$

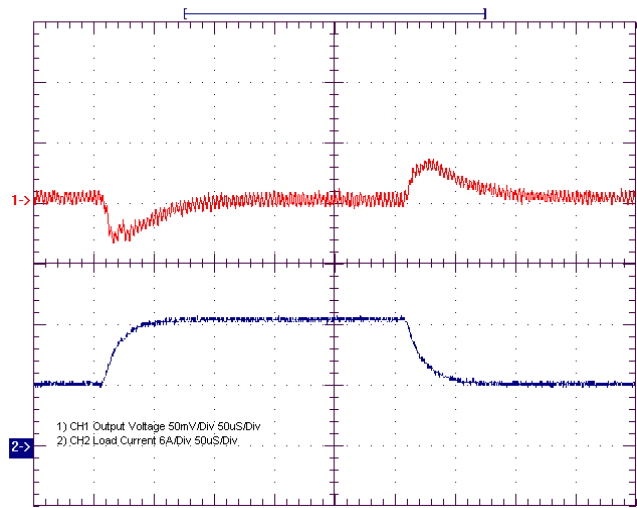

Output Ripple (see test configuration)

$V_{IN}=5V, V_{OUT}=3.3V, 12A \text{ Load, } C_{IN}/C_{OUT} = 0$

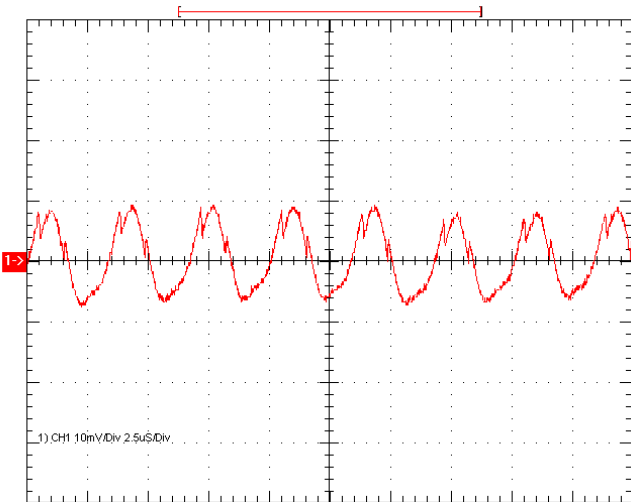

$V_{IN}=5.0V, V_{OUT}=2.5V, 12A \text{ Load, } C_{IN}/C_{OUT} = 0$

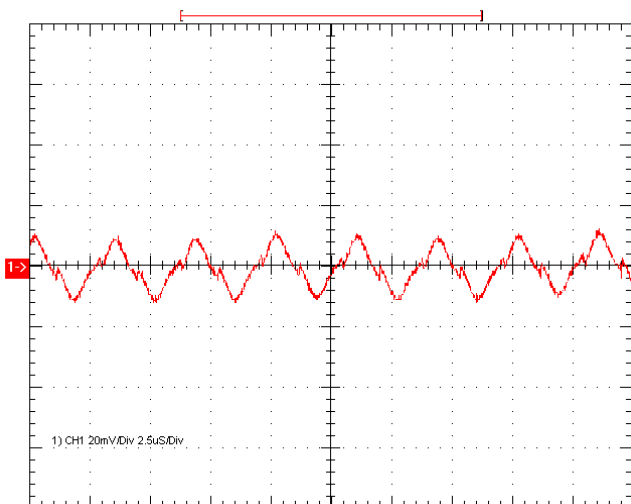

$V_{IN}=3.3V, V_{OUT}=2.5V, 12A \text{ Load, } C_{IN}/C_{OUT} = 0$

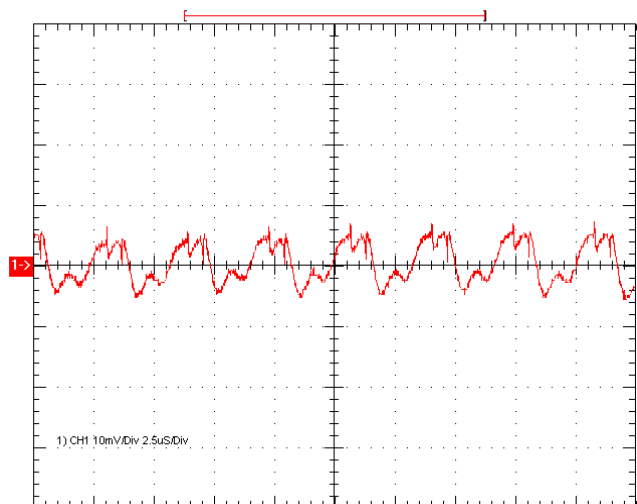

$V_{IN}=5.0V, V_{OUT}=1.8V, 12A \text{ Load}, C_{IN}/C_{OUT} = 0$

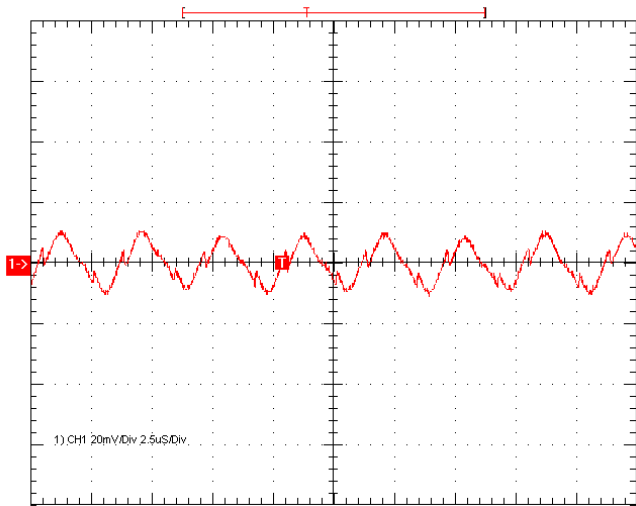

$V_{IN}=3.3V, V_{OUT}=1.8V, 12A \text{ Load}, C_{IN}/C_{OUT} = 0$

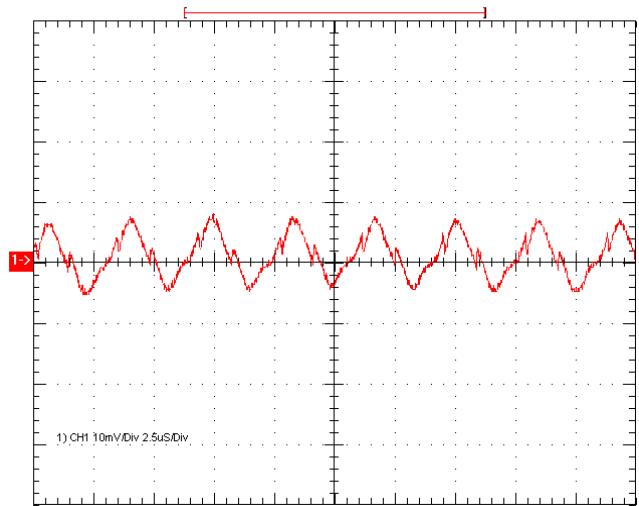

$V_{IN}=5.0V, V_{OUT}=1.5V, 12A \text{ Load}, C_{IN}/C_{OUT} = 0$

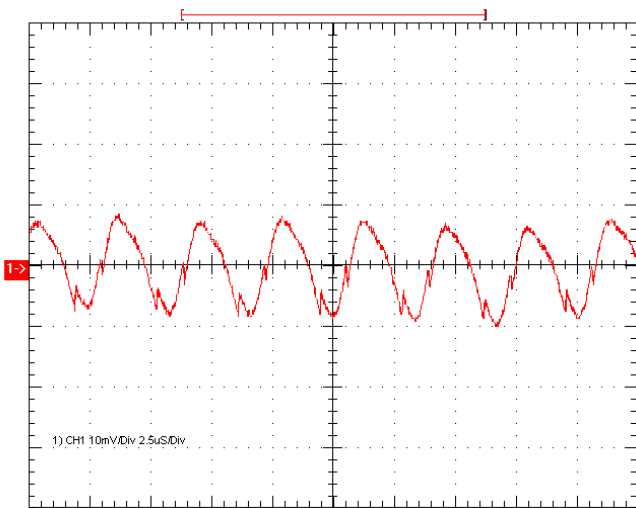

$V_{IN}=3.3V, V_{OUT}=1.5V, 12A \text{ Load}, C_{IN}/C_{OUT} = 0$

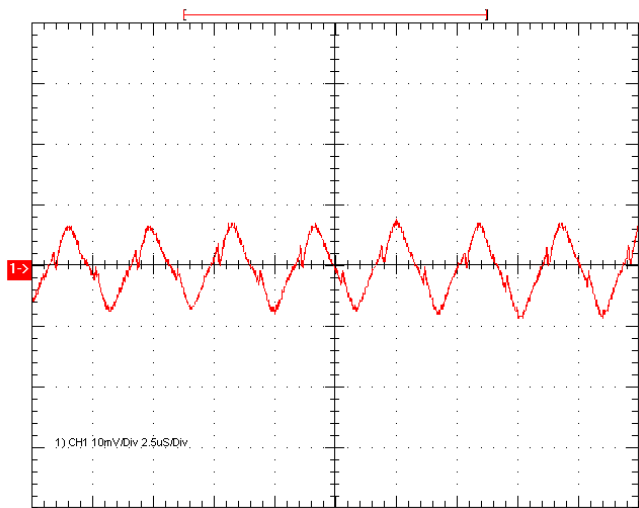

$V_{IN}=5.0V, V_{OUT}=1.2V, 12A \text{ Load}, C_{IN}/C_{OUT} = 0$

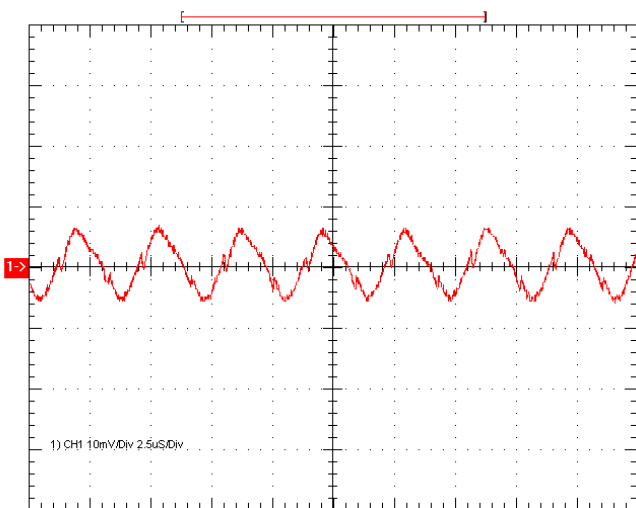

$V_{IN}=3.3V, V_{OUT}=1.2V, 12A \text{ Load}, C_{IN}/C_{OUT} = 0$

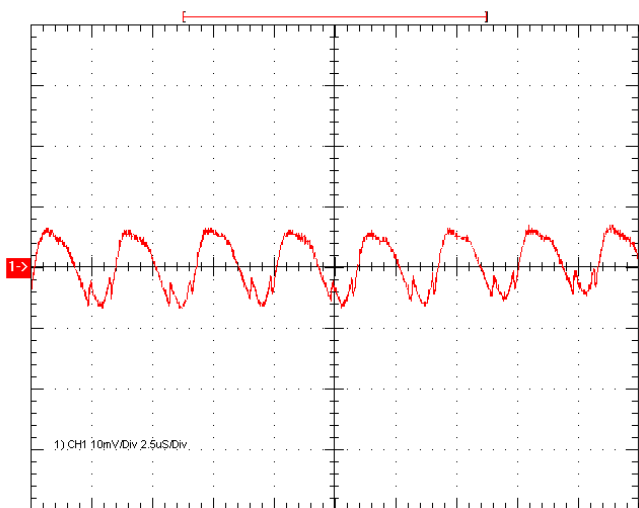

$V_{IN}=5.0V, V_{OUT}=1.0V, 12A \text{ Load}, C_{IN}/C_{OUT} = 0$

$V_{IN}=3.3V, V_{OUT}=1.0V, 12A \text{ Load}, C_{IN}/C_{OUT} = 0$

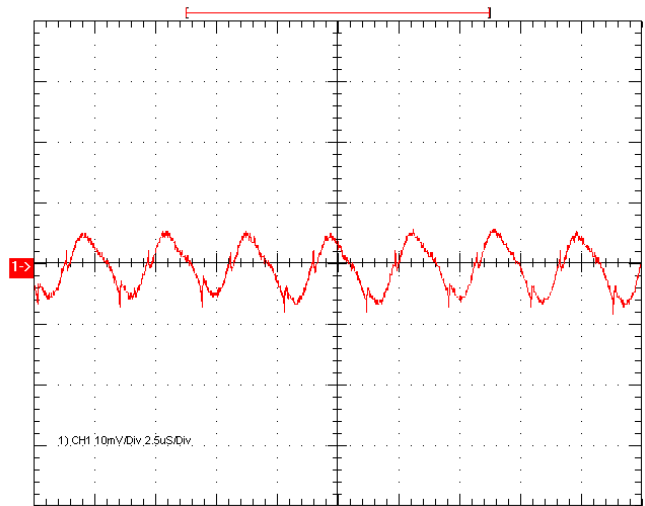
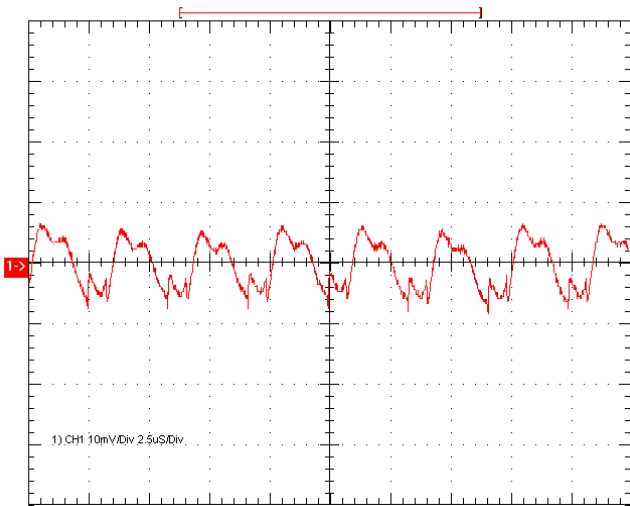

Power-up

$V_{IN}=3.3V \text{ Applied}, V_{OUT}=2.5V, 12A \text{ Load}, C_{IN}/C_{OUT} = 0$

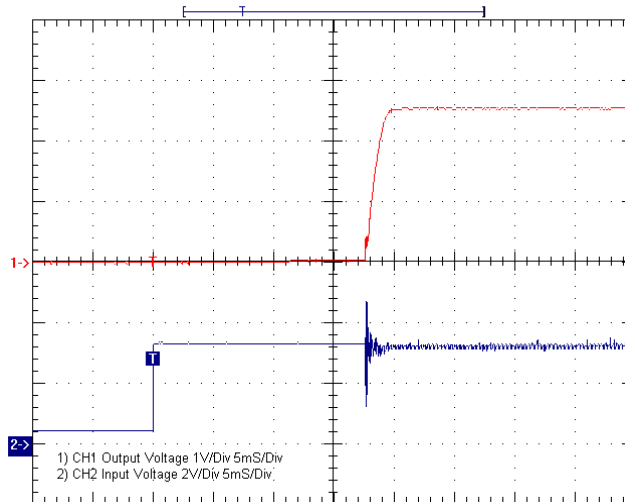

Recommended Hole Pattern

Dimensions are in inches (millimeters)

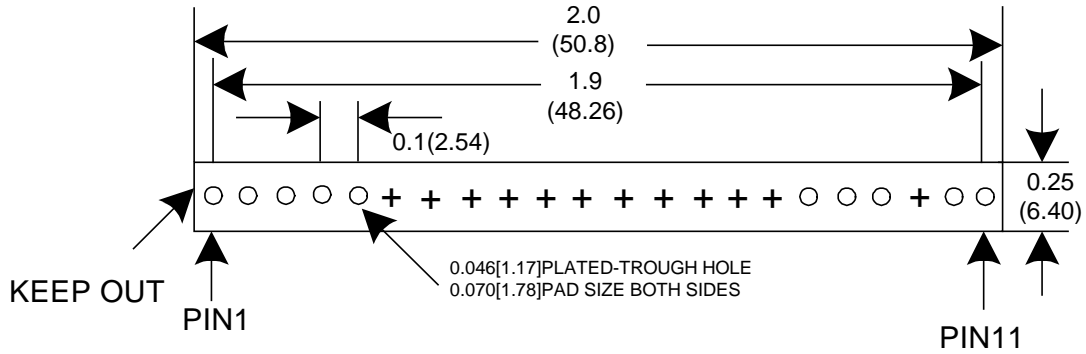

Component-side footprint

Mechanical Specifications for "R" suffix

Dimensions are in inches (millimeters)

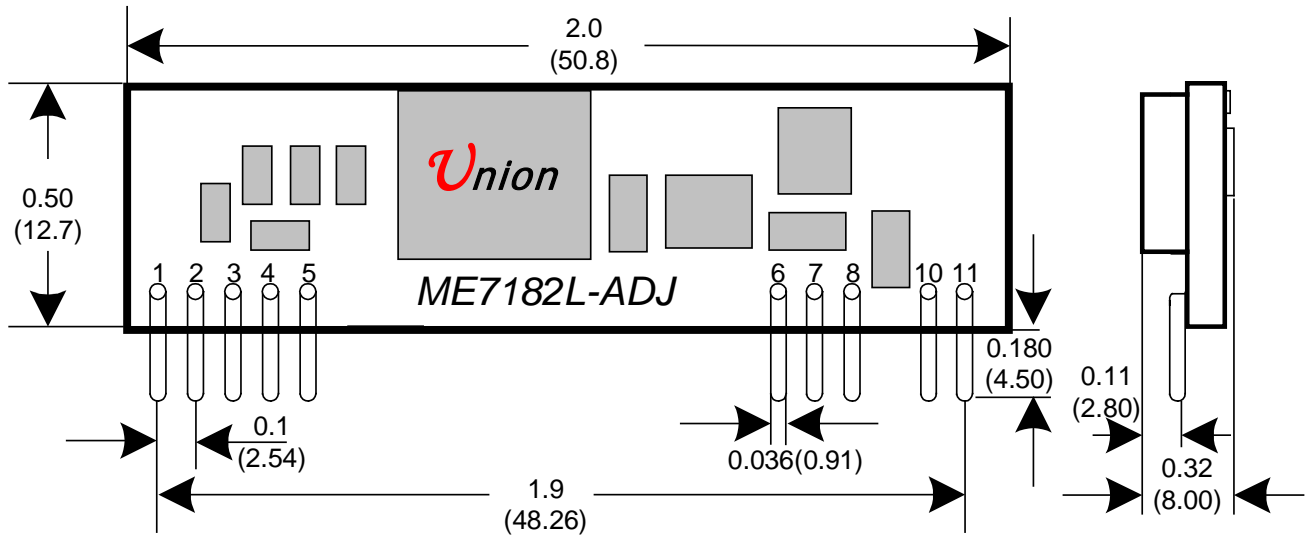

Recommended Hole Pattern for "R" suffix

Dimensions are in inches (millimeters)

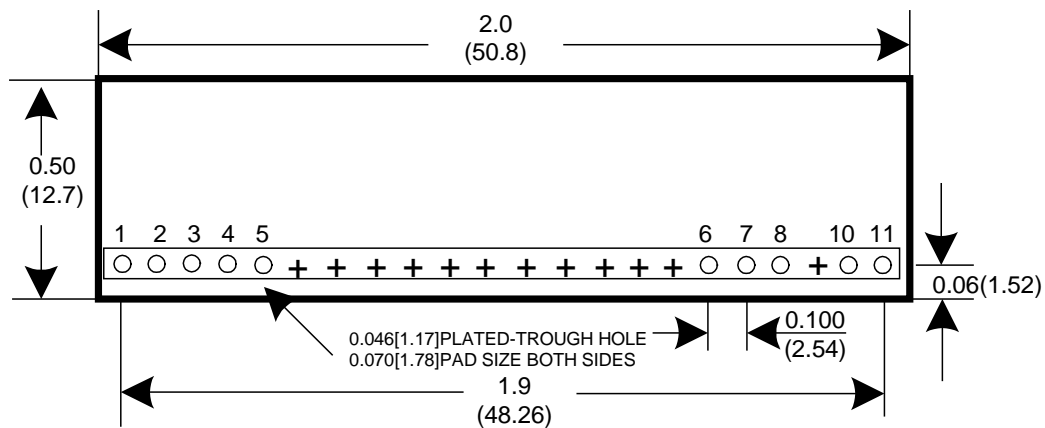

Component-side footprint

